



TYPE AT-4, SERIES A, FOOT SWITCH

DESCRIPTION

The type AT-4 is a four position foot switch designed primarily for use with Class 5060 AT brakes and controllers. This foot switch provides four individual, sequential operating points. Each operating point has one normally open and one normally closed electrical circuit.

INSTALLATION & ADJUSTMENT

Mount the foot switch on a flat, rigid surface.

The operating points of the foot switch are pre-set at the factory. No further adjustments should be required. However, minor adjustments can be made to the point at which a snap switch trips by slightly bending the roller arm on that snap switch. Bending the roller closer to the snap switch body, will cause the switch to trip at a greater foot pedal travel.

REPAIR & MAINTENANCE

SNAP-SWITCH REPLACEMENT.

If a snap switch becomes defective, or a roller operator does not function properly, replace the entire snap switch and operator assembly as follows:

1. Loosen screw (A) and remove cover (1).
2. Remove two screws (5).
3. Remove snap-switch assembly (4).
4. Install new snap switch assembly, fasten with two screws (5).
5. Replace cover (1) and tighten screw (A).

Caution: The snap switch assembly must be oriented such that the roller on the operator faces outward and down.

CAM REPLACEMENT

In the event that a cam becomes worn, it should be replaced. Follow this procedure:

1. Loosen screw (A) and remove cover (1).
2. Remove two screws (19) holding left side plate (23).
3. Remove left side plate (23).
4. Remove roll pin (24).
5. Remove worn cam (25, 26) and replace with new cam.
6. Replace roll pin (24).
7. Replace left side plate (23) and fasten with two screws (19).
8. Replace cover (1) and tighten screw (A).

Caution: Orient cams such that the word "OFF" is at the top and the smaller notch is to the left.

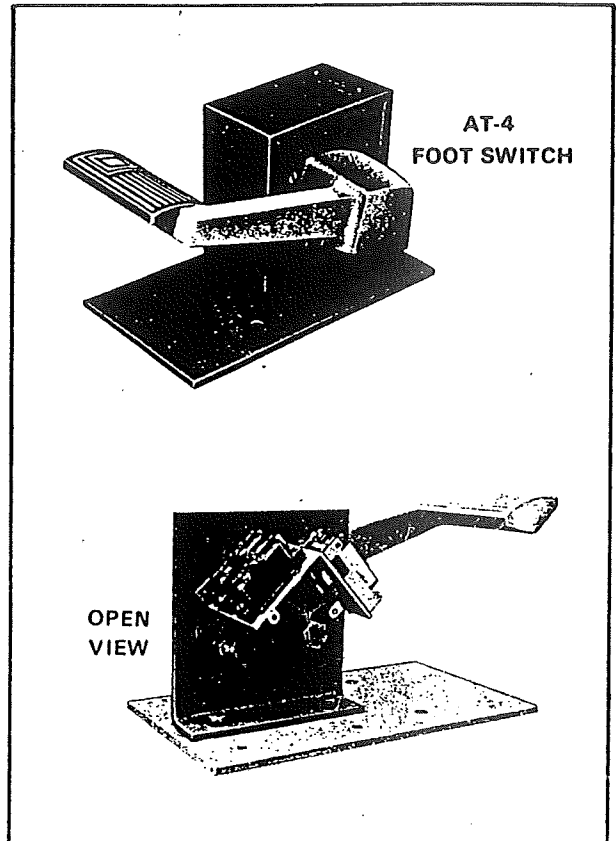

TORSION SPRING REPLACEMENT

The pedal return torsion spring is located under the foot pedal. To replace this spring proceed as follows:

1. Loosen screw (A) and remove cover (1).
2. Slightly depress the foot pedal and remove pedal stop (11) and screw (12).
3. Let foot pedal come up until all the tension is off the torsion spring.
4. Drive out roll pin (16) and remove foot pedal (17) and spring (15).
5. Coat replacement spring with lubricating grease and replace spring and foot pedal.
6. Line-up hole in foot pedal and shaft and replace roll pin (16).
7. Depress foot pedal and replace pedal stop (11) and screw (12).
8. Replace cover (1) and tighten screw (A).

LUBRICATION

The sleeve bearings on this foot switch are lubricated at the factory so that further lubrication will not be required for a long time. However, it is recommended that any time that the foot switch is taken apart, the shaft and bearings be cleaned and re-oiled.



TYPE AT-4, SERIES A, FOOT SWITCH

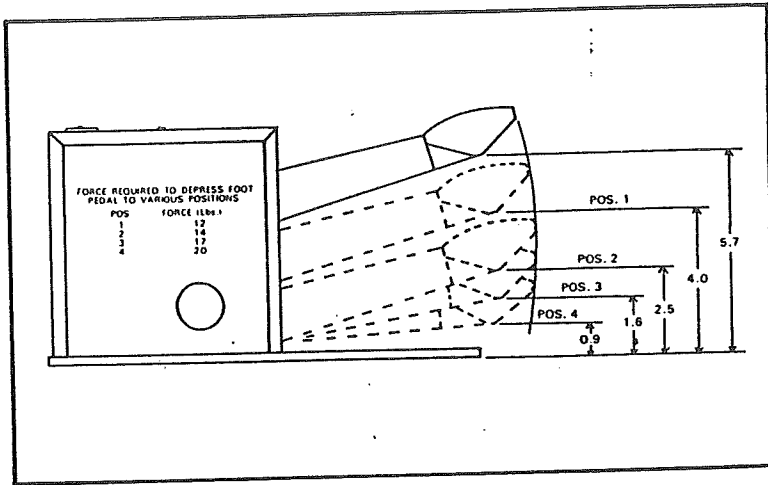

FOOT SWITCH PEDAL POSITIONS

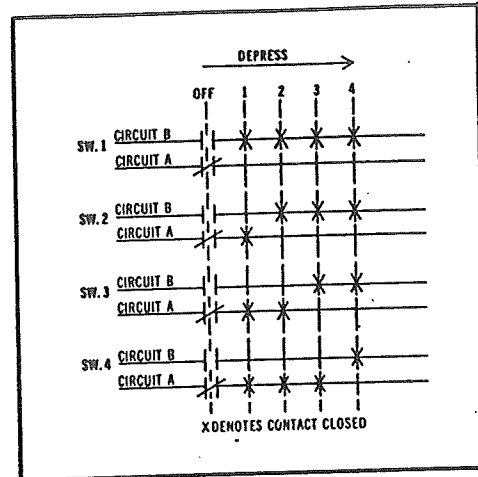

FOOT SWITCH CONTACT SEQUENCE

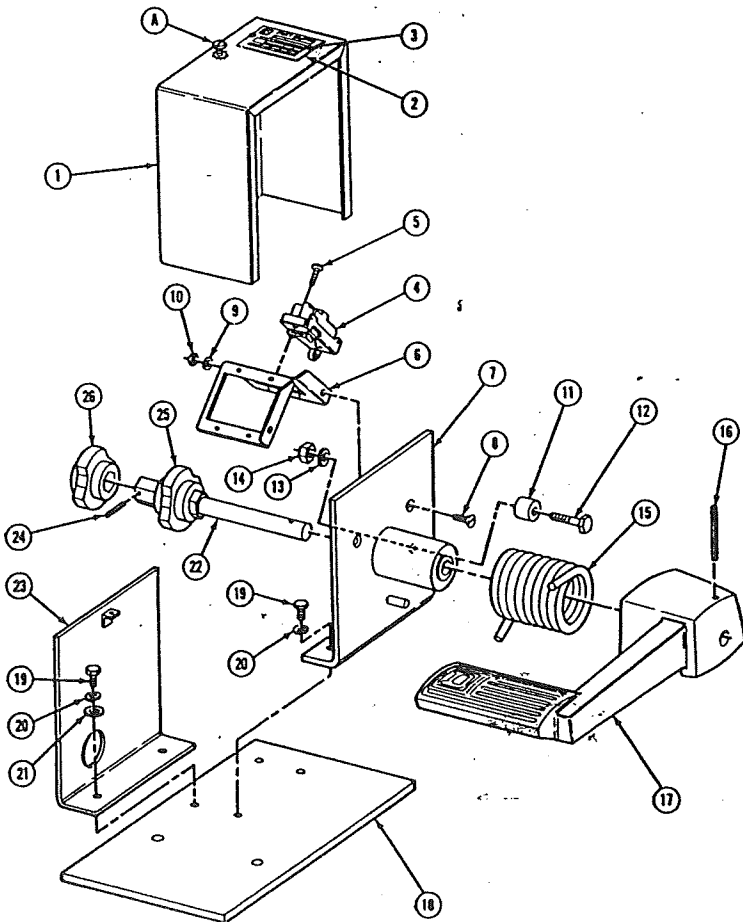

Item No.	Part No.	Description
1	A5-1091-030-50	Assembled Cover
2	A5-1139-139-01	Nameplate
3	21008-04060	#4 Drive Screw, 2 Req'd.
4	Class 9007 Type AB-21	Snap Switch with Roller, 4 Req'd.
5	21590-12200	#6-32 x 5/8 Thread Form. Scr., 8 Req'd.
6	B5-1091-029-01	Switch Mounting Bracket
7	A5-1091-022-51	Assembled Frame
8	21201-20200	1/4"-20 x 5/8 Flat Hd. Stl. Scr., 2 Req'd.
9	23701-00200	1/4" Lock Washer, 2 Req'd.
10	23002-00200	1/4"-20 Stl. Hex Nut, 2 Req'd.
11	B5-0502-051-36	Stop
12	21401-24400	3/8"-16 x 1 1/4 Hex Hd. Stl. Scr.
13	23701-00240	3/8" Lock Washer
14	23002-00240	3/8"-16 Stl. Hex Nut
15	A5-1091-028-01	Spring
16	24209-12560	3/16" x 1 1/4 Roll Pin
17	C5-1091-032-01	Foot Pedal
18	A5-1091-021-01	Base
19	21401-22160	5/16"-18 x 1/2 Hex Hd. Stl. Scr., 4 Req'd.
20	23701-00220	5/16" Lock Washer, 4 Req'd.
21	23601-00220	5/16" Plain Washer, 2 Req'd.
22	A5-1091-026-01	Cam Shaft
23	A5-1091-025-50	Assembled Side Plate
24	24209-08401	1/8" x 1 1/4 Roll Pin
25	A5-1091-027-01	Cam
26	A5-1091-027-02	Cam
A	214-D30-G1	#8 - 32 x 9/16 Stl. Scr. & Lock Washer Assembly